

JR SERIES ALARM – FITTING INSTRUCTIONS.

Description

The JR-A Series alarm and JR-B and C Alarm Immobiliser comprise of-

- A. Control Box
- B. Selected Siren
- C. Two Key Fobs
- D. Pre wired sonic sensing heads
- E. All necessary wiring looms and LED Bezel
- F. Full instructions.

Installation of Components

The siren must be mounted securely under the bonnet away from hot components such as exhaust manifolds and away from areas that can suffer from water spray. Positioning must also be such that the siren is not muffled but can easily be accessible when the key operated option is installed. The cable should be neatly tie wrapped with black cable ties so that it will blend into the original wiring, then passed through the 'Bulk head' into the interior of the vehicle, no electrical connection is required to be made under the bonnet and all connections **must** be made inside the vehicle.

The main control unit **must** be located inside the vehicle so that after wiring has been completed it can be fixed where it cannot be easily damaged or accessed.

The ultrasonic transducers should be mounted securely and positioned away from air vents but making sure that full coverage of the interior of the vehicle can be achieved. Often two thirds up the windscreen A posts is suitable. The transducer heads should be angled towards the inside of the vehicle. The sensor leads should be trapped neatly under the capping until they arrive under the dashboard, the leads should be passed through to the am in control box, being secured neatly with the tie wraps where suitable.

Connections

The first connection that must be made is the **Earth** connection. This must be achieved by crimping an Eyelet securely onto the alarms earth wire, making sure the conductor is well gripped and not just the cables insulation. The Eyelet must be bolted onto the main earthing stud, fastening this to any other panel or bracket is NOT acceptable as although it may appear Earthed this cannot be guaranteed as sound and often may cause malfunction or damage.

The main positive should be connected to a feed fused between 20-30 amps, a lower rated supply will result in the integrity of the alarm condition not be maintained in the event of the indicator outputs being shorted. It is recommended that a method of overriding the system be incorporated into the installation due to the secure nature of the alarm, to prevent user dissatisfaction if they should lose or break their remote key fob. All main loom connections must be soldered carefully and insulated with heat shrink. The use of "Scotch-Lok" type or Screw type connections must **never** be used.

Where the siren is connected to the siren loom using crimp 'Butts' the connections must be inspected to ensure the integrity of the crimp. The joined cable must be formed into a loop and tie wrapped to itself to avoid any strain being placed on the joint if the ends of the wire are pulled. All cables should be cut to optimum length to ensure they can be organised neatly and safely to avoid entanglement with mechanical linkages, such as foot pedals and steering column etc.

When using any data sheet to identify the wiring for specific connections on the vehicle these must only be used as a guide as they can often prove inaccurate due to the constant development by vehicle manufactures. The wiring must be checked using a multi meter prior to connections with the alarm. A test lamp must not be used as it may not show low current signals and may even damage systems within the car. The details of the wiring loom with reference to the colour follows.

Particular care should be taken to avoid interference with safety systems, such as Airbags, ABS, Seatbelt Tensioners etc. The rest of the wiring should be completed by referring to the appropriate following diagrams before plugging the loom into the control box.

After all connections have been completed refer to the section on dipswitch set up sequence. Initially ensure dip switches 1,6,7,8 and 9 are up and 2,3,4 and 5 are down, plug in the loom and check out all the basic functions.

Then configure the CDL modes if applicable and check out the operation. Finally set up the passive models required bearing in mind the combinations listed are finite and a complete selection from any line must be used.

The installation can now be completed. Refer to the User Instructions where clarifications of details of operation are required. Please ensure the customer pack includes both key fobs, user instructions and JR Autoquote are given to the buyer and in line with the user instructions inform them of the method of overriding the system if incorporated.

If any key fob fails to operate the system, press for several seconds until a panic condition arises, i.e. the alarm triggers. A further press will bring the alarm and the key fob back into synchronisation.

FUNCTION	COLOUR	DESCRIPTION	RATING amps
12v permanent positive supply	Red (Black alarm side of fuse)	Main alarm supply must be taken from min 20A supply	20 Non Continuous
EARTH (Negative supply) Note Loom must not be plugged into alarm until this connection has been securely made	Black	Main alarm negative supply must be taken from vehicle manufacturers earthing stud and tightly secured via securely crimped eyelet	20 Non Continuous
LED	Pre-wired (Twin Black)	Tri coloured status LED	N/A
LH Indicator	Orange	Outputs positive supply	5 Pulsed
RH Indicator	Orange	Outputs positive supply	5 Pulsed
Primary Pin Switch	Pink	Detects negative input must be used on all relevant openings whether passive or auto re-arming is used	N/A
Change of State Pin Switch	Brown	Input can be positive, negative, or not connected, once the alarm have set, changing the state will trigger the system. This can be used for positive switched & normally open contact switches i.e. non standard & commercial applications. NB This pin switch will not influence passive & auto re-arming	N/A
Auxiliary Output	Blue	When the alarm is armed this wire becomes negative. When the alarm is disarmed no output is present. This can be used for accessories. NB. On JR-C model this output can be set to 30 second timed (see dip switch setting). This will not output when alarm arms passively. <u>Window lifts should not be used with passive arming & auto re-arming for safety reasons relating to unexpected closing of windows.</u>	1
Ignition Sense	White	Should be connected to a supply that becomes positive when ignition is on. Required for safety circuits, connect securely	N/A
Immobiliser Circuit 1	2 x Black	Wires become open circuit when immobilised	10
Immobiliser Circuit 2	2 x Black	Wires become open circuit when immobilised	
CDL Lock	Blue/Black	Output vehicle dependent, should be set by reference to dip switch selection table	10 Intermittent
CDL Unlock	Red/White	Output vehicle dependant, should be set by reference to dip switch selection table	10 Intermittent

The wire loop at the side of the siren socket should only be cut when the alarm is used in conjunction with sirens that incorporate override facilities.

JR-A LOOM

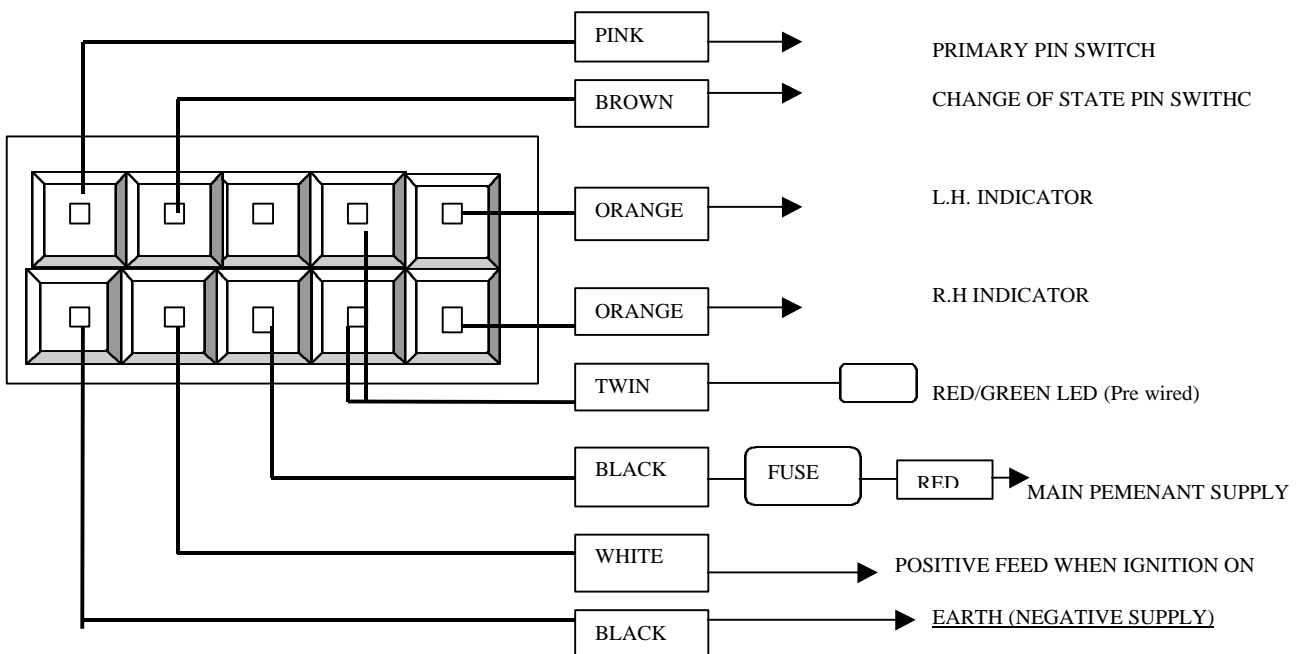

JR-B & C LOOM

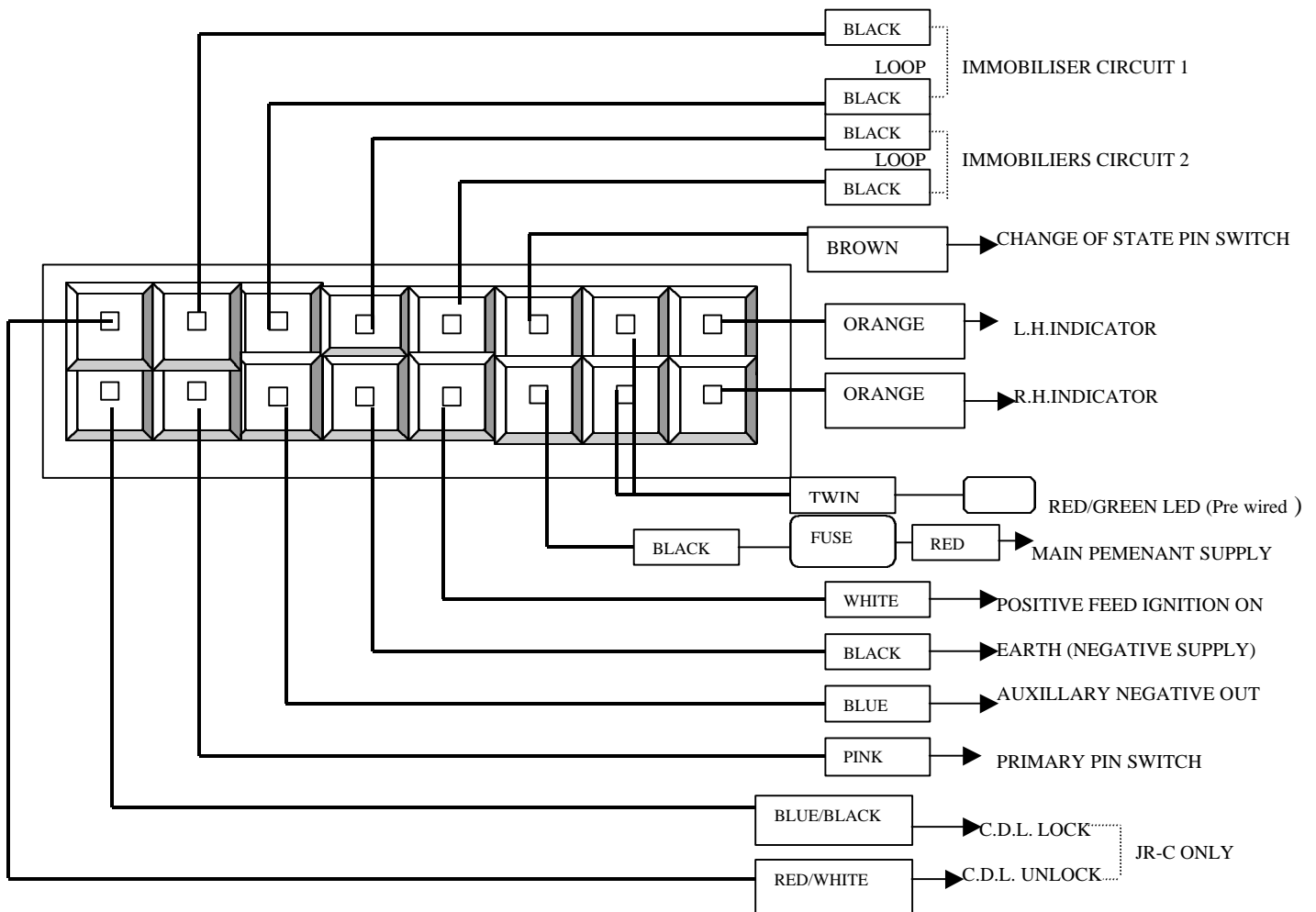

1-3 SIREN

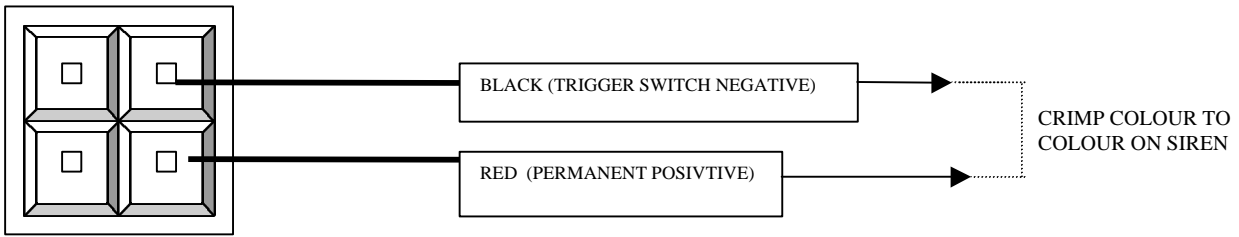

4 SIREN

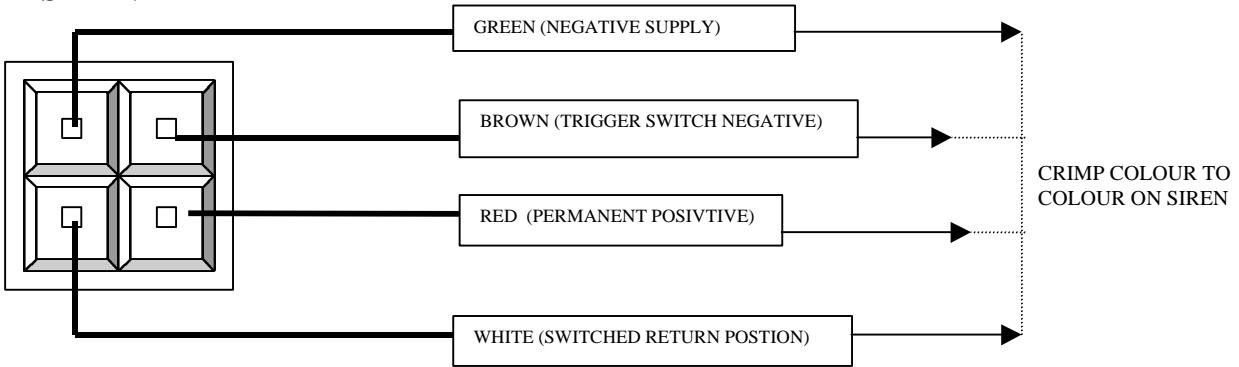

5 SIREN

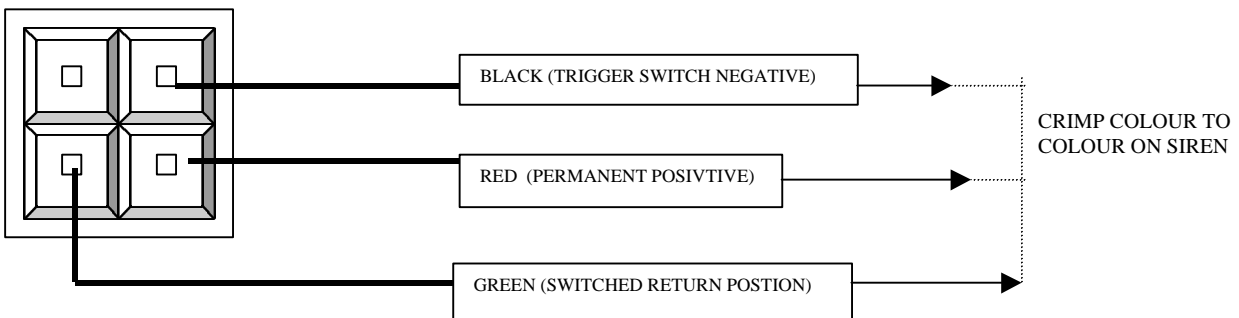

Function Buttons

The **Function Buttons** on the rear of the unit are momentary action and are used to gain access to **Diagnostics**, **Radio Key Fob Coding (Additional)** and **Radio Key Re-coding**. The buttons can be depressed using gentle pressure applied with a small screwdriver or similar tool. Using these buttons it is possible to read the non-volatile memory to determine the cause of the last alarm condition and add/delete radio keys.

For the function buttons to be operational the alarm must be off and the ignition on.

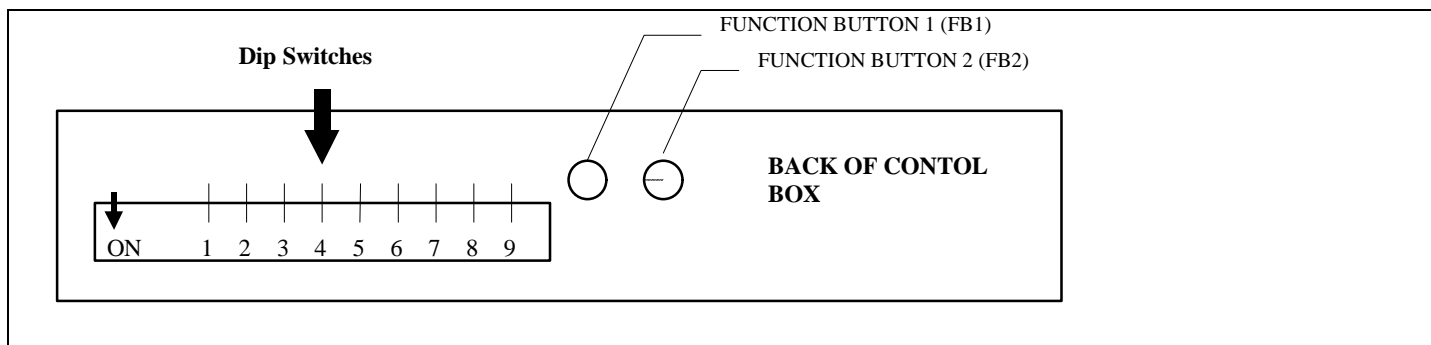

Diagnostics

To determine the cause of the last alarm condition depress function button 1 for approximately 3 seconds, the LED will flash green and the pattern will repeat a further 4 times. Note the last alarm condition will only be recorded if the alarm has remained sounding for 6 seconds minimum.

Number of Flashes	1	2	3	4	5	6	7
Cause of last alarm	None	Pin switch (Brown)	Pin switch (Pink)	Volt drop sensing	Ultrasonic	Panic	Ignition activated

Radio Key Fob Coding (Additional)

Tools: - Small Screwdriver or similar tool

The alarm has the ability to have up to 4 randomly encrypted key fobs and comes with 2 coded fobs. If an additional fob is required, turn on the ignition and depress function button 2 for approximately 3 seconds. The LED will flash orange a number of times depending on the number of fobs already in the system i.e. the system would normally be coded with 2 fobs and the LED would flash 3 times indicating the alarm is asking for a third fob to be added. Immediately press and keep pressed the fob to be added, the LED on the fob will pulse for approximately 10 seconds then a continuing flicker on the LED will be observed. At the end of the coding cycle, the LED on the vehicle will light Orange for approximately 3 seconds, and then normal operation of the alarm will resume. To confirm successful coding of the alarm, turn the ignition off, press fob, for approximately 10 seconds, until the alarm triggers. Normal operation will then be resumed. If the coding procedure is entered and the response is 1 Orange flash lasting 3 seconds no additional fob can be added, as the system is already full.

Radio Key Re-coding

Tool required: pointed nose pliers.

If the system is to be completely re-coded e.g. if the fobs are lost or known to be stolen, the following procedure should be carried out. Turn on ignitions, depress simultaneously both function buttons for approximately 3 seconds until the LED flashes Orange once, this confirms the system is clean and ready to accept new codes. Next press and keep pressed the 1st fob, the LED on the fob will pulse for approximately 10 seconds then a continuous flicker on the LED will be observed. After the valid code has been accepted the LED will flash twice asking for a second key fob. If only one fob is available repeat the coding procedure with the same fob. (2 fobs minimum are required). After acceptance of the second fob the LED on the vehicle will flash Orange 3 times asking for a third fob. If a third fob is not required, after approximately 15 seconds, the LED will flash Orange for approximately 3 seconds, and then normal operation will be resumed. The re-coded fobs will operate normally after a couple of presses. Turn ignition off, press fob until a continuous flicker, which will trigger the alarm and then press again until the alarm goes off.

Note. As the integrity of the alarm is maintained after disconnection and reconnection of power to the system, designed to enhance the security of the system, it is unlikely but possible to have a situation where the alarm is set and the radio keys are lost. In this case to allow fobs to be coded, the positive supply to the alarm must be disconnected, both function buttons depressed together and held down whilst power is reconnected. The LED will flash Orange once, indicating that new fobs must be entered.

Dip Switch Set Up Sequence

Volt Drop Control

Dip Switch 1	
Up	No volt drop detection
Down	Volt drop detection

Set Tone

Dip Switch 2	
Up	No audible tone on set
Down	Audible tone on set

Passive Modes

Dip Switch 3	Dip Switch 4	Dip Switch 5	
DOWN	DOWN	DOWN	No passive modes operational
DOWN	DOWN	UP	Passive immobilisation only
DOWN	UP	DOWN	Passive immobilisation & passive arming
DOWN	UP	UP	Passive immobilisation & auto re-arming
UP	DOWN	DOWN	Passive immobilisation, passive arming & auto re-arming
UP	DOWN	UP	Passive immobilisation & auto-lock
UP	UP	DOWN	Passive immobilisation, auto re-arming & auto lock
UP	UP	UP	Passive immobilisation, passive arming, auto re arming, auto lock

NB: Immobilisation & auto lock modes not applicable on JR-A Model. Auto lock mode not applicable on JR-B Model

Central Door Locking Modes – JR-C ONLY

Dip Switch 6	Dip Switch 7	Dip Switch 8	
DOWN	DOWN	DOWN	1.2 second negative lock/1.2 second negative unlock
DOWN	DOWN	UP	1.2 second positive lock/1.2 second positive unlock
DOWN	UP	DOWN	Actuator
UP	DOWN	DOWN	0.25 second negative lock/0.25 second negative unlock
UP	DOWN	UP	30 second positive lock/1.2 second positive unlock
UP	UP	DOWN	30 second negative lock/0.25 second negative unlock
UP	UP	UP	No output to CDL
DOWN	UP	UP	Vacuum

Timed Negative Output - JR-C ONLY

Dip Switch 9		
UP	30 Second time negative output	<p>Note when using vacuum locking the cable running from the door locking micro switch should be cut. The free end leading to the switch should be connected to the change of state (brown) pin switch wire from the alarm and the free end leading to the CDL pump should be connected to the lock wire (blue/black) from the alarm. Using this configuration, Pin Switches cannot be connected to the brown wire.</p>
DOWN	Permanent negative output	

NB: If 30 second option has been selected, no negative output will occur if the system arms passively.